

## Roller Inspection Table

### Description

The Watson & Brookman Roller Inspection Table provides a hygienic platform for 360° product inspection. A series of chain-mounted rollers gently rotate product as it is carried along the length of the inspection table.

Waste troughs either side of the table allow for disposal of waste or reject product. The waste troughs can also be integrated into a bespoke waste removal or re-peel system.



Long uninterrupted sides and wide rollers allow for the maximum number of operators around the table.



### Construction

Fully stainless steel hygienic construction as standard. Fully guarded side covers allow for easy and safe access to the rollers and drive components and for cleaning and maintenance.

Guard switches can also be integrated into a master line safety circuit.

## Technical Specification

|                           | <b>2000-600</b>   | <b>2000-900</b>   | <b>3000-600</b>   | <b>3000-900</b>   |
|---------------------------|---|---|---|---|
| <b>Capacity</b>           | Up to 2000/Hr   | Up to 2000Kg/Hr   | Up to 2500Kg/Hr   | Up to 3000Kg/Hr   |
| <b>Product Infeed</b>     | Continuous  | Continuous  | Continuous  | Continuous  |
| <b>Dimensions (LxWxH)</b> | 2013 x 1232 x 1016  | 2013 x 1482 x 1016  | 3013 x 1232 x 1016  | 3013 x 1494 x 1016  |
| <b>Power Consumption</b>  | 0.37Kw, 230/400V,<br>50Hz                                 | 0.37Kw, 230/400V,<br>50Hz                                 | 0.37Kw, 230/400V,<br>50Hz                                 | 0.37Kw, 230/400V,<br>50Hz                                 |
| <b>Materials</b>          | Stainless steel bead<br>blasted. Sealed<br>bearing units. | Stainless steel bead<br>blasted. Sealed<br>bearing units. | Stainless steel bead<br>blasted. Sealed<br>bearing units. | Stainless steel bead<br>blasted. Sealed<br>bearing units. |

## Dimensional Drawing

|              | <b>2000-600</b> | <b>2000-900</b> | <b>3000-600</b> | <b>3000-900</b> |
|--------------|-----------------|-----------------|-----------------|-----------------|
| <b>Dim A</b> | 2013            | 2013            | 3013            | 3013            |
| <b>Dim B</b> | 1232            | 1482            | 1232            | 1494            |
| <b>Dim C</b> | 1016            | 1016            | 1016            | 1016            |
| <b>Dim D</b> | 600             | 900             | 600             | 900             |

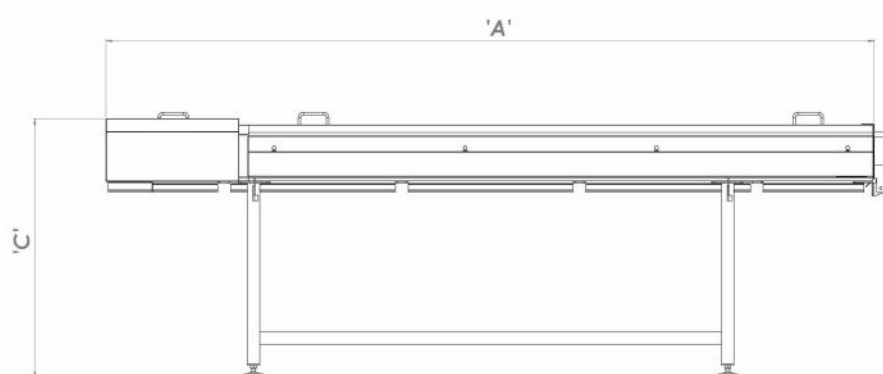
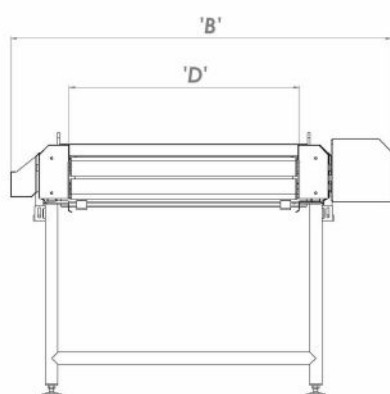

*All dimensions are approximate*

*If you have any further questions, please contact our Sales Team.*